



特种计算机

Industrial Computer

产品说明书

User Manual

CPC-8408B

6U 8-Slot CPCI 机箱

6U 8-Slot CPCI Chassis

Version: C00

法律资讯

警告提示

为了您的人身安全以及避免财产损失，必须注意本手册中的提示。人身安全的提示用一个警告三角表示，仅与财产损失有关的提示不带警告三角。警告提示根据危险等级由高到低如下表示。

 危险

表示如果不采取相应的小心措施，将会导致死亡或者严重的人身伤害。

 警告

表示如果不采取相应的小心措施，可能导致死亡或者严重的人身伤害。

 小心

带有警告三角，表示如果不采取相应的小心措施，可能导致轻微的人身伤害。

注意

表示如果不注意相应的提示，可能会出现不希望的结果或状态。

合格的专业人员

本文件所属的产品/系统只允许由符合各项工作要求的合格人员进行操作。其操作必须遵照各自附带的文件说明，特别是其中的安全及警告提示。由于具备相关培训及经验，合格人员可以察觉本产品/系统的风险，并避免可能的危险。

EVOC产品

请注意下列说明：

 警告

EVOC产品只允许用于目录和相关技术文件中规定的使用情况。如果要使用其他公司的产品和组件，必须得到EVOC推荐和允许。正确的运输、储存、组装、装配、安装、调试、操作和维护是产品安全、正常运行的前提。必须保证允许的环境条件。必须注意相关文件中的提示。
--



免责声明

本公司保留对此手册更改的权利，产品后续相关变更时，恕不另行通知。对于任何因安装、使用不当而导致的直接、间接、有意或无意的损坏及隐患概不负责。

订购产品前，请向经销商详细了解产品性能是否符合您的需求。

EVOC 是研祥智能科技股份有限公司的注册商标。本手册所涉及到的其他商标，其所有权为相应的产品厂家所拥有。

研祥智能科技股份有限公司©2012，版权所有，违者必究。未经许可，不得以机械、电子或其它任何方式进行复制。

保修条款：

产品保修期一年。用户如另有要求，以双方签署的合同为准。

欲获更多信息请访问：

研祥网站：<http://www.evoc.com>

研祥技术支持邮箱：support@evoc.com（国际）、support@evoc.cn（国内）

免费客服热线： 4008809666

文档说明

本文档适用范围

本文档适用于EVOC CPC-8408B型号。

约定

在本文档中，术语“整机”或“产品”有时特指EVOC CPC-8408B产品。

说明

安全相关注意事项

为避免财产损失以及出于个人安全方面的原因，请注意本入门指南中关于安全方面的信息。文中使用警告三角来指示这些安全信息，警告三角的出现取决于潜在危险的程度。

目 录

1.产品介绍	1
1.1 产品概述	1
1.2 产品规格	1
2.应用规划	3
2.1 运输	3
2.2 贮存	3
2.3 开箱及检查交付的设备	3
2.4 安装方式	4
3.设备连接	5
3.1 连接前的注意事项	5
3.2 产品接地	5
3.3 将设备连接到电源	6
4.使用说明	7
4.1 产品外观图	7
4.2 产品外形及安装尺寸图	7
4.3 外部结构图	8
4.4 操作控件	9
5.拆装与维护	10
5.1 整体装配图	10
5.2 前插卡/后插卡拆装	11
5.2.1 前插卡/后插卡安装	11
5.2.2 前插卡/后插卡拆卸	11
5.3 驱动器拆装	12
5.4 电源拆装	13
5.5 风扇及防尘网拆装与维护	14
6.驱动程序安装说明	16
7. 附录	17
7.1 常见故障分析与解决	17

1. 产品介绍

1.1 产品概述

CPC-8408B 是一款 4U 高、8 个 6U 水平插卡 CompactPCI 机箱，支持 PICMG2.0、PICMG2.1 规范。机箱右边有一个可插拔风扇模块，采用吹风散热方式。机箱包含 2 个 3U 可插拔 CPCI 电源，2 个可抽拉硬盘模块。提供一个高可靠性、高稳定性、高容量的 CPCI 通讯平台。

机箱采用冷轧不锈钢板折弯成形，结构简单，具有良好的防尘、散热、抗振及 EMC 性能，系统可靠性高，环境适用性强。

产品可广泛应用于通讯、军工、测控等多个领域。

1.2 产品规格

项目		定义
主要性能指标	外形尺寸 (不含挂耳)	外形尺寸： 481.7mm（宽）×177mm（高）×400.6mm（深）
	重量	16.1 Kg
	温度	工作温度：-5℃ ~ 55℃ 存储温度：-40℃ ~ 85℃
	湿度	5%~95%（非凝结状态）
	电磁兼容性	<ul style="list-style-type: none"> ● 无线电骚扰限值符合 GB9254-2008 标准 A 级； ● 抗扰度符合 GB/T 17618-1998 标准的限值。
	可靠性	<ul style="list-style-type: none"> ● 平均无故障工作时间：MTBF≥50000h； ● 平均维修时间：MTTR≤0.5h。
	安全性	满足 GB4943 的基本要求。

	机械环境适应性	<ul style="list-style-type: none">● 抗振动: 5-19Hz/1.0mm 振幅; 19-200Hz/1.0g 加速度;● 抗冲击: 10g 加速度, 11ms 周期;
	电源特性	<ul style="list-style-type: none">● 输入电压/频率: 220VAC/50Hz;

2. 应用规划

2.1 运输

包装好的产品能以任何交通工具，运往任何地点，在长途运输时不得装在敞开的船舱和车厢中，中途转运时不得存放在露天仓库中，在运输过程中不允许和易燃、易爆、易腐蚀的物品同车（或其他运输工具）装运，并且产品不允许经受雨、雪或液体物质的淋湿与机械损坏。

2.2 贮存

产品贮存时应存放在原包装箱内，存放产品的仓库环境温度为 0℃~40℃，相对湿度为 20%~85%。仓库内不允许有各种有害气体、易燃、易爆炸的产品及有腐蚀性的化学物品，并且无强烈的机械振动、冲击和强磁场作用。包装箱应垫离地面至少 10cm，距离墙壁、热源、冷源、窗口或空气入口至少 50cm。

小心

损坏设备的风险！

在寒冷天气状况下运输 PC 时，应注意温度的极端变化。这种情况下，请确保设备上或设备内部没有形成水滴（凝露）。如果设备上形成了凝露，请在接通设备前至少等待 12 个小时。

2.3 开箱及检查交付的设备

设备开箱

设备开箱时请注意以下几点：

- 建议您不要丢弃原包装材料。请保留原包装材料以备再次运输设备时使用。
- 请将文档存放在安全的地方。初始调试设备时需用到该文档，并且它是设备的一部分。
- 检查交付的设备，查看是否在运输途中造成了任何明显的损坏。
- 验证所运货物是否包含完整的设备以及您单独订购的附件。如有任何不符或存在运输损坏，请联系客户服务人员。

2.4 安装方式

- 19" 上架式 桌面式（台面式） 嵌入面板式
- 壁挂式 VESA 标准支撑臂 手提便携式
- 其他方式_____

3. 设备连接

3.1 连接前的注意事项

警告

所连接或内置的外围设备不得接入极性相反的设备。

警告

本设备只能在接地电源网络上运行。禁止在未接地或阻抗接地的电源网络上进行操作。

警告

使用的设备额定电压必须符合本产品电源特性。

注意

只能连接经认可适合工业应用的外围设备。PC 运行时，可以连接热插拔 I/O 模块（USB）。无热插拔功能的 I/O 设备只能在设备断开电源后进行连接。

3.2 产品接地

低阻抗接地连接更有助于将外部电缆、信号电缆或连接 I/O 模块的电缆所生成的干扰释放到接地系统。

接地端子

设备上的接地端子 ① 必须与安装有 PC 的机柜或设备的中央接地母线连接。最小导线横截面不能小于 5mm^2 。

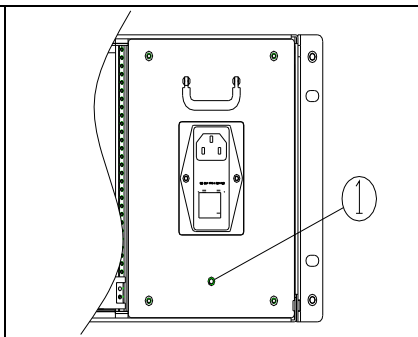

3.3 将设备连接到电源

将设备连接到电源的步骤

插入电源线时确保电源开关
② 位于“0”（关闭）位置，
以避免设备意外启动。

将电源线连接到该插口①并
接通电源开关 ②，设备启动。

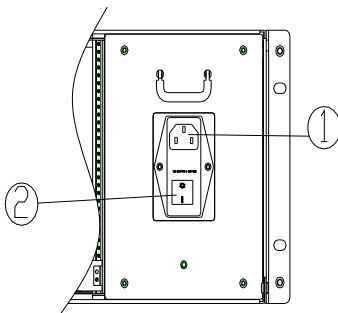

危险

雷暴雨期间断开电源和数据电缆。

注意

必须断开电源连接器才能将设备与电源完全隔离。

4. 使用说明

4.1 产品外观图

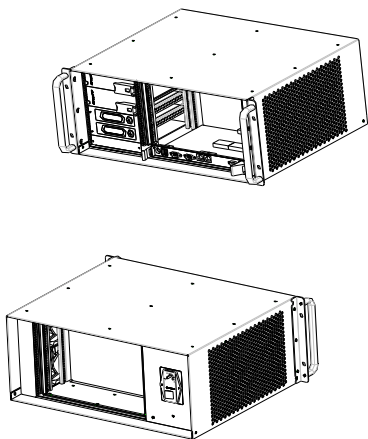

4.2 产品外形及安装尺寸图

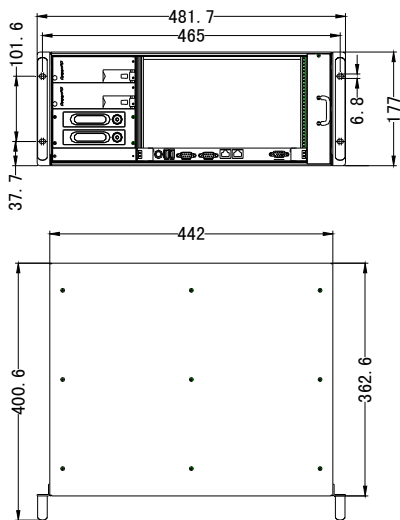

单位：mm

4.3 外部结构图

设备的正视图	项目	描述
	①	可抽拉风扇模块
	②	扩展槽位
	③	可抽拉硬盘模块
	④	3U CPCI 电源

设备的后视图	项目	描述
	①	电源开关
	②	扩展插槽

4.4 操作控件

⚠警告

开/关按钮信号不会切断 PC 电源！

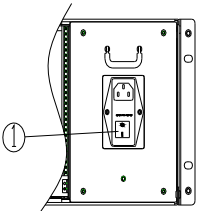
控件按钮	项目	描述
	<p>①</p>	<p>用于启动或关闭设备的开/关按钮。</p>

5. 拆装与维护

5.1 整体装配图

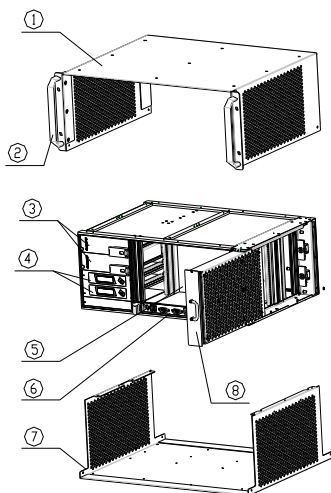

项目	描述	项目	描述
1	上盖	2	把手
3	CPCI 电源	4	硬盘模块
5	背板	6	CPCI 主板
7	机箱底板	8	风扇模块

5.2 前插卡/后插卡拆装

5.2.1 前插卡/后插卡安装

所配置任何插卡都必须符合背板信号定义和 PICMG 规范的机械结构标准，在插卡上推荐使用经过良好 EMC 设计的面板和带锁定装置的把手。

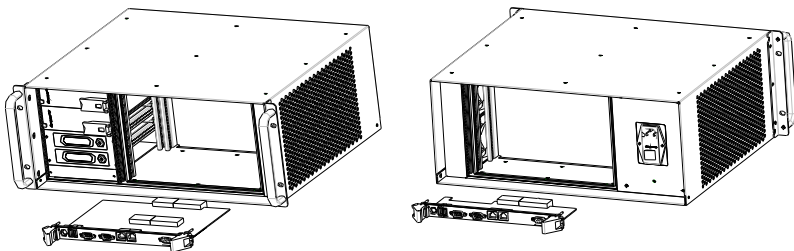

- 1) 插入前插卡/后插卡时请务必按如下操作：
 1. 双手拿稳前插卡/后插卡面板，元件面朝上；
 2. 在对应插槽位置沿导轨轻轻推入；
 3. 当接近背板连接器时，双手分别按住面板把手的锁定装置并向外侧打开，然后再向内侧用力扣住机箱并同时向里推面板；
 4. 确认推进到位，把手锁定在机箱上。

5.2.2 前插卡/后插卡拆卸

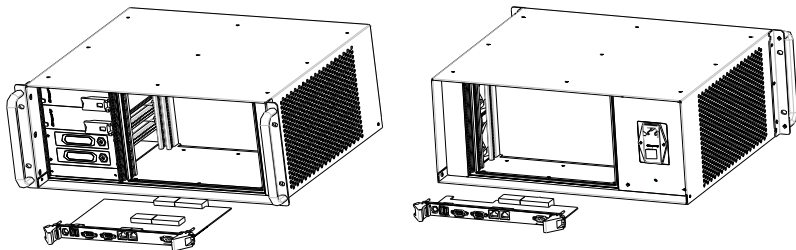

- 1) 拔出前插卡/后插卡时请务必按如下操作：

1. 双手分别按住把手的锁定装置并向外侧打开，扣住机箱，向外用力拔出至脱离背板连接器；
2. 沿导轨取出插卡，放置到安全位置。

5.3 驱动器拆装

- 1) 如果需要更换系统硬盘，需要关闭系统电源。更换其他硬盘，无需关闭系统电源。用钥匙打开锁，用手指按住抽屉门中央的嵌入式手柄的左侧，使手柄翘出，握住手柄直接将硬盘连同硬盘抽屉拔出；（如下图）

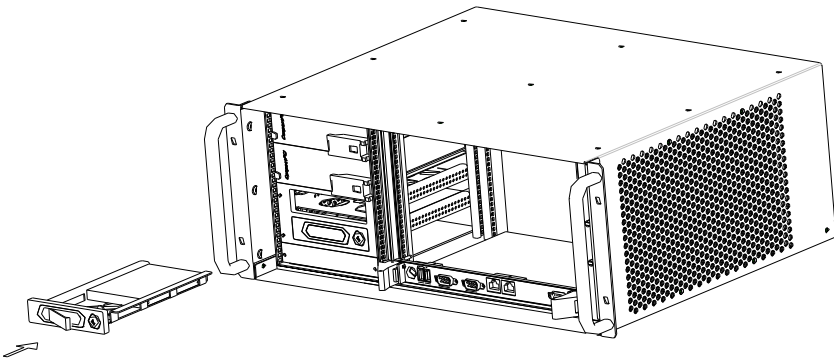

- 2) 如果更换硬盘，拆掉固定硬盘的4颗螺丝，取出硬盘并放置在安全的位置，更换需要的硬盘；如果安装新硬盘，需要固定好这四颗螺丝。（注意：螺丝采用M3沉头螺丝，确保螺丝锁紧后螺丝头面与硬盘导轨架底面平齐。）

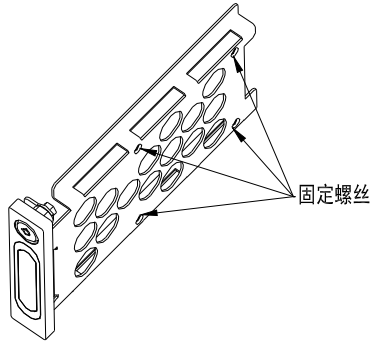

- 3) 重新将安装好的硬盘及硬盘抽屉插入机箱，确保硬盘与背板上的连接器连接好后，用钥匙锁好，确保锁舌进入固定孔位。
- 4) 系统识别硬盘后，即可正常使用。

5.4 电源拆装



危险

拆卸电源模块前，若有电源接入，则必须关闭电源，拆除电源线。

CPC-8408B 在出厂前已经把专用的电源模块安装在机箱内，如果需要更换请按如下步骤操作：

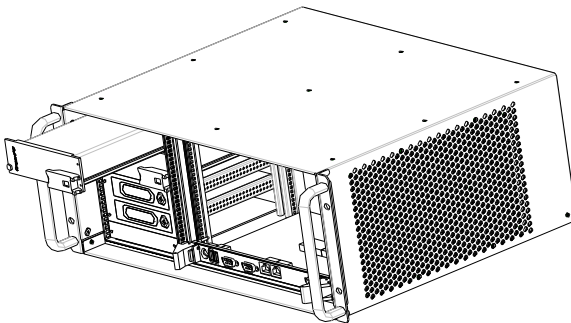

- 1) 松动电源模块面板上的固定螺丝使之完全脱离机箱；

- 2) 向外侧拉开电源模块把手直到脱离背板连接器，沿导轨抽出电源模块，并用专用包装材料包装好；
- 3) 确认新电源模块的输入方式符合系统使用要求；
- 4) 确认面板把手成打开状态，沿导轨轻轻把电源模块插入机箱直到面板把手卡钩进入机箱固定孔，然后拿稳面板把手向内侧用力把电源压入直到把手成缩紧状态；
- 5) 电源模块插紧后，用螺丝把面板固定在机箱上；
- 6) 观察电源模块面板上的指示灯，显示正常后即可开始使用。

5.5 风扇及防尘网拆装与维护

注意

由于风扇的转速较快，所以在风扇停止转动之前，禁止用手触摸风扇。

风扇在使用过程中，如风扇和防尘网损坏，需要更换，需先停机后再进行更换，具体步骤如下：

- 1) 卸下风扇前面板螺丝，用手指握住风扇前面板把手，将整个风扇模块从机箱中拔出(如图所示)；

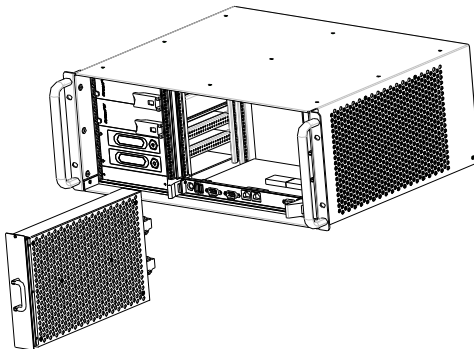

- 2) 如要更换防尘网只需卸掉如下图所示序号7 风扇支架固定螺丝，将风扇支架连同风扇整体取出即可；如要更换风扇须继续卸掉如下图所示序号4 风扇锁紧螺丝，将风扇更换后，按原样装配好装机即可使用。

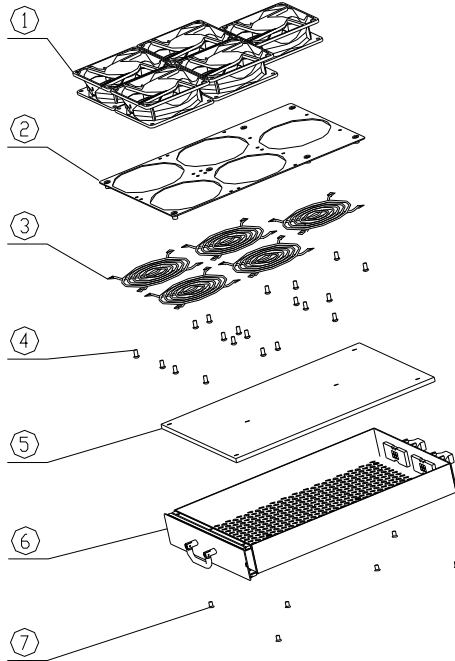

项目	描述	项目	描述
1	风扇	2	风扇支架
3	风扇网罩	4	风扇锁紧螺丝
5	防尘网	6	风扇模块主体
7	风扇支架固定螺丝		

6. 驱动程序安装说明

本产品的驱动程序安装及主板详细信息请参考整机配套光盘，在此不做介绍。

7. 附录

7.1 常见故障分析与解决

常见故障	可能原因	故障解决方法
设备不能运行	无电源	请检查电源和电源线/连接器
	设备运行不符合指定的环境条件	1、检查环境条件 2、在开启冷天运输的设备之前请等待大约 12 小时。
外接显示器不亮	显示器未打开	打开显示器
	显示器处于“节电”模式	按键盘上的任意键
	亮度控件被设置为黑暗状态	通过亮度控件提高亮度。有关详细信息,可参考显示器操作说明。
	未连接电源线或显示器电缆	1、检查电源线是否正确地连接到显示器和系统单元或接地出口。 2、检查显示器电缆是否正确地连接到系统单元和显示器。 3、如果执行这些检查后显示器屏幕仍不亮,请与技术支持联系。
PC 上的时间或日期不正确。	BIOS 设置不正确	根据开机画面提示的按键,打开 BIOS Setup,在 BIOS Setup 中调整时间和日期。
BIOS 设置正确,时间和日期不对。	备用电池电量不足	更换电池

USB 设备不响应	在 BIOS 中已禁用 USB 端口	使用不同的 USB 端口或启用该端口。
	连接了 USB 2.0 设备, 但禁用了 USB 2.0。	启用 USB 2.0。
	操作系统不支持 USB 端口。	1、为鼠标和键盘启用 USB Legacy Support (支持传统 USB)。 2、对其它设备, 需要有适合操作系统的 USB 驱动程序。
计算机未启动或显示 Boot device not found	在 BIOS 设置的启动优先级中, 该启动设备不是第一优先级, 或者未包括在启动设备中。	在 BIOS 设置的“启动”(Boot) 菜单中更改该启动设备的启动优先级, 或将该启动设备包括在启动优先级中。
开机提示找不到系统盘	硬盘电源线或数据线未接好	检查硬盘(硬盘必须是已经装好系统可引导的)的电源线、数据线是否插好。
	硬盘系统文件损坏	用可引导的光盘进入系统(常用 winpe 系统), 检查硬盘系统是否已损坏, 有必要时最好重新安装系统。
即插即用 I/O 卡设备, 再次使用时检测不到或不能正常使用。	插槽接触不良	一般是由于 PCI 或 ISA 卡频繁的拔插、固定不稳、防尘措施不好等造成插槽接触不良所致, 可反复拔插几次或者换个槽插。

Legal Information

Warnings

Please pay attention to the tips within the manual so as to avoid personal injury or property losses. The tips for personal injury are indicated in warning triangles while the tips only related to property losses have no warning triangles. The warning tips are listed as follows with the hazardous scale from severe to slight.



Danger

If handled carelessly, death or severe human injury will occur.



Warning

If handled carelessly, death or severe human injury might occur.



Caution

Warning triangle indicates that slight human injury might occur if handled carelessly.

Note

Unexpected result or status might occur, if not handled according to the tips.

Professional Personnel

The product/system covered by the manual can only be handled by qualified and professional personnel. During operation, please follow the respective instructive manuals, especially the safety warnings. The professional personnel have been trained and possess relevant experiences; therefore, he/she could be aware of the risks of the product/system and avoid possible damages.

EVOC Product

Please pay attention to the following instructions:



Warning

EVOC product can only be used according to the descriptions within the manual, including the contents and the relevant technical documents. If the products or components from other companies are required, please get the recommendation and grant from EVOC first. Proper transportation, storage, assembly, installation, debugging, operation and maintenance are prerequisite to ensure product safety and normal operation; therefore, please ensure permitted environment conditions and pay attention to the tips within the manual.



Copyright Notice

Information offered in this manual is believed to be correct at the time of printing, and is subject to change without prior notice in order to improve reliability, design and function and does not represent a commitment on the part of the manufacturer. In no event will the manufacturer be liable for direct, indirect, special, incidental, or consequential damages arising out of improper installation and/or use, or inability to use the product or documentation.

This user manual is protected by copyright. No part of this manual may be reproduced, stored in any retrieval system, or transmitted, in any form or by any means, mechanical, electronic, photocopied, recorded or otherwise, without the prior written permission from the manufacturer.

Trademarks

EVOC is a registered trademark of EVOC Intelligent Technology Co., Ltd. Other product names mentioned herein are used for identification purposes only and may be trademark and/or registered trademarks of their respective companies.

Warranty Terms:

The warranty on the product lasts for one year. If the user has additional requirements, the contract signed between the two sides shall prevail.

Please visit our website: <http://www.evoc.com> for more information, or send an email to the Technical Support Mailbox support@evoc.com (International) or support@evoc.cn (Domestic) for consultation.

Hotline: 4008809666

About this manual

Scope of the Manual

The manual is appropriate for EVOC CPC-8408B.

Convention

The term “the Board” or “the Product” within the manual stands for EVOC CPC-8408B.

Instructions

Safety instructions

To avoid property losses or individual injury, please pay attention to the safety instructions within the manual. The warnings within the manual are marked with warning triangle , which is dependent upon the scale of the potential hazard.

C o n t e n t s

1. Product Introduction	1
1.1 Overview	1
1.2 Product Specifications	1
2. Application Scheme	3
2.1 Transportation	3
2.2 Storage	3
2.3 Opening the Box and Initial Examination	4
2.4 Mounting Mode	4
3. Device Connection.....	5
3.1 Notices before Connection.....	5
3.2 Product Grounding.....	5
3.3 Connecting the Device to Power.....	6
4. Instructions	7
4.1 Product Outline	7
4.2 Product Appearance and Installation Dimensions.....	7
4.3 External Structure	8
4.4 Operation Control	9
5. Assembly and Maintenance	10
5.1 Overall Assembly Drawing.....	10
5.2 Removal and Installation of Front/Rear Add-in Card	11
5.2.1 Installing the Front/Rear Add-in Card.....	11
5.2.2 Removing the Front/Rear Add-in Card	12
5.3 Removal and Installation of Driver.....	12
5.4 Removal and Installation of Power Supply.....	13
5.5 Assembly and Maintenance of Fan and Dust-proof Net.....	14
6. Installing the Drivers	16
7. Appendix.....	17
7.1 Troubleshooting and Solutions.....	17

1. Product Introduction

1.1 Overview

CPC-8408B is a 4U CompactPCI chassis, supporting eight 6U horizontal add-in cards, which supports PICMG2.0 and PICMG2.1 standards. One pluggable fan module is configured on the right of the chassis, which adopts air-blowing mode to dissipate heat. The chassis include two 3U pluggable CPCI power supplies and two drawable hard disk modules; thus, the product provides a highly reliable, highly stable and high capacity CPCI communication platform.

The chassis adopts cold-rolled stainless sheet metal and is bent to form; it features simple structure, excellent dust-proof, heat dissipation, anti-vibration, EMC performance, high system reliability and strong environmental adaptability.

The product can be widely applied in various fields such as communication, military, measurement and control, etc.

1.2 Product Specifications

Items		Definitions
Main Performance Index	Dimensions (excluding the hangers)	Dimensions: 481.7mm (W) x 177mm (H) x 400.6mm (D)
	Weight	16.1 Kg
	Temperature	Operating Temperature: -5°C ~ 55°C Storage Temperature: -40°C ~ 85°C
	Humidity	5% ~ 95% (non-condensing)
	EMC	<ul style="list-style-type: none"> ● Limits of radio disturbance are compliant with GB9254-2008, class A; ● Limits of immunity are compliant with the threshold of GB/T 17618-1998;

Reliability	<ul style="list-style-type: none"> ● MTBF\geq50000h; ● MTTR\leq0.5h.
Safety	Meets the basic requirements of GB4943;
Mechanical and Environment Adaptability	<ul style="list-style-type: none"> ● Anti-vibration: 5-19Hz/1.0mm amplitude; 19-200Hz/1.0g acceleration; ● Anti-shock: 10g acceleration, 11ms duration.
Power Feature	<ul style="list-style-type: none"> ● Input Voltage/Frequency: 220VAC/50Hz;

2. Application Scheme

2.1 Transportation

Well-packaged products are suited for transportation by all kinds of vehicles. During transportation, products should not be put in open cabin or carriage. During transshipping, products should not be stored in open air without protection from the atmospheric conditions. Products should not be transported together with inflammable, explosive and corrosive substances and are not allowed to be exposed to rain, snow and liquid substances and mechanical force.

2.2 Storage

Products should be stored in package box when it is not used. And warehouse temperature should be 0°C ~ 40°C, and relative humidity should be 20% ~ 85%. In the warehouse, there should be no harmful gas, inflammable, explosive products, and corrosive chemical products, and strong mechanical vibration, shock and strong magnetic field interference. The package box should be at least 10cm above ground, and 50cm away from wall, thermal source, window and air inlet.

Caution
Risk of destroying the device!
When shipping the PC in cold weather, please pay attention to the extreme temperature variation. Under this circumstance, please make sure no water drop (condensation) is formed on the surface or interior of the device. If condensation is formed on the device, please wait for over twelve hours before connecting the device.

2.3 Opening the Box and Initial Examination

Opening the Box

Please pay attention to the following issues when opening the box:

- Do not discard the original packing material. Please keep the original packing material for re-transportation.
- Please keep the documentation at a safe place. The documentation is required for initial device debugging, which is a component of the device.
- When doing the initial examination, please check whether there are distinct damages to the device caused during the transport.
- Please check whether the delivery contains the intact device and all of the independently ordered accessories. Please contact the customer service when any nonconformity or transportation damages occur.

2.4 Mounting Mode

- 19" Rack Mount Desktop Embedded Panel
 Wall Mount VESA Standard Arm Portable
 Others _____

3. Device Connection

3.1 Notices before Connection

Warning

The connected or built-in peripherals with opposite polarities are not allowed.

Warning

The device only operates when connecting with grounded power. No operation is allowed when the device power is ungrounded or only impedance is grounded.

Warning

Rated voltage of the device in use shall be in accord with power feature of the product.

Note:

Only the peripheral devices approved for industrial application can be used. When operating the PC, hot swappable IO modules (USB) can be used. The IO devices without hot swap function can only be connected when the PC is powered off.

3.2 Product Grounding

Low impedance ground connection is more helpful to release the interference produced by the external cables, the signal cables or the cables connecting the IO module to the grounding system.

Ground Terminals

The grounding terminal ① on the device shall be connected with the cabinet installed with the PC or the central grounding busbar on the device. The minimum cross section area of the cable shall be no less than 5mm².

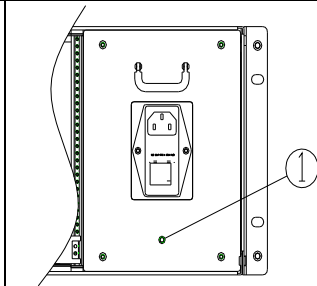

3.3 Connecting the Device to Power

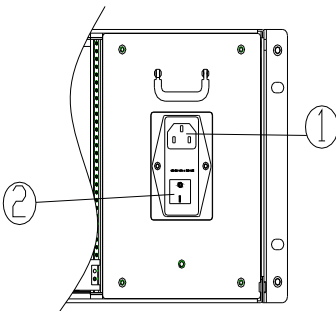
Steps to connect the device to power:	
Make sure the power switch ② is turned to “0” (Off) when connecting the power cord, so as to avoid accidental powering on.	
Connect the power cord with the connector ① and turn the power switch ② to power on the device.	

 **Danger**

Please disconnect the power and data cables during thunder storm.

Note:

To completely isolate the device from the power supply, please disconnect the power connector.

4. Instructions

4.1 Product Outline

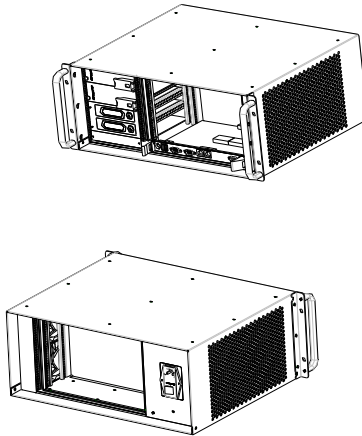

4.2 Product Appearance and Installation Dimensions

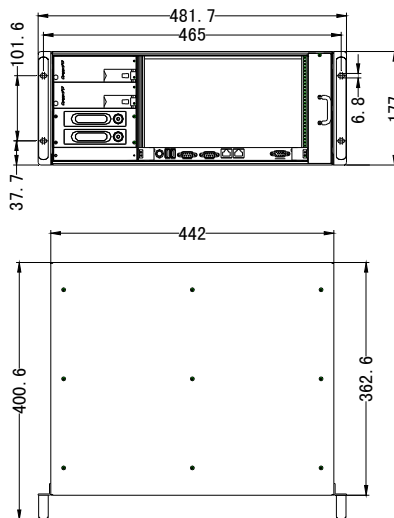

Unit: mm

4.3 External Structure

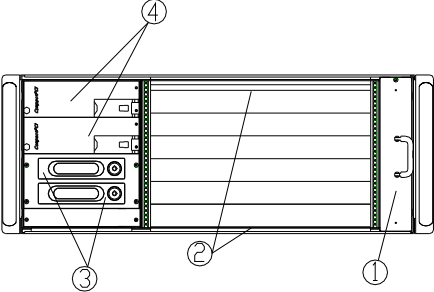
Front View	Item	Description
	①	Drawable fan module
	②	Expansion slot
	③	Drawable HDD module
	④	3U CPCI power

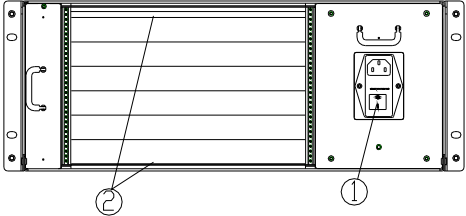
Rear View	Item	Description
	①	Power switch
	②	Expansion slot

4.4 Operation Control

⚠ Warning

Pressing On/Off button won't cut off the power of the PC!

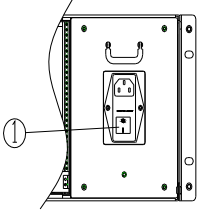
Control Button	Item	Description
	<p>①</p>	<p>The button is used to power on or power off the device.</p>

5. Assembly and Maintenance

5.1 Overall Assembly Drawing

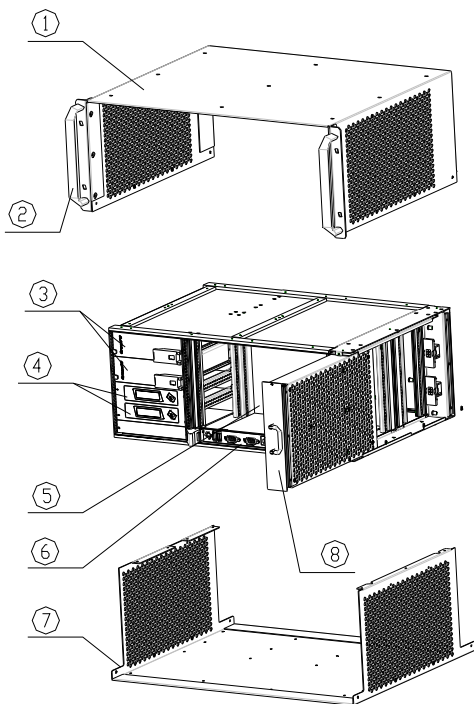

Item	Description	Item	Description
1	Upper Cover	2	Handle
3	CPCI Power Supply	4	HDD Module
5	Backplane	6	CPCI Motherboard
7	Chassis Carrier	8	Fan Module

5.2 Removal and Installation of Front/Rear Add-in Card

5.2.1 Installing the Front/Rear Add-in Card

All the add-in cards shall meet the backplane signal definitions and the PICMG mechanical and structural standards. It is recommended to use the panel with excellent EMC design and the handle with locking device.

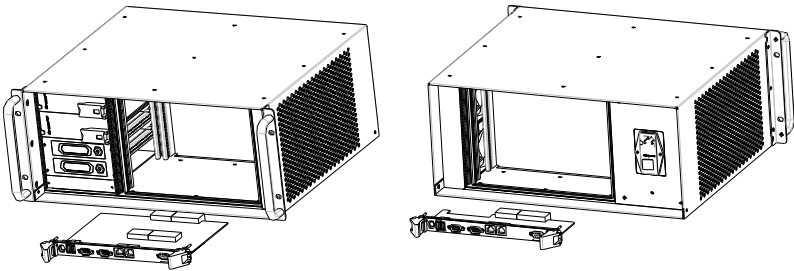

- 1) When installing the front/rear add-in cards, please do as follows:
 1. Stably hold the panel of the front/rear add-in cards by both hands with the component side facing up;
 2. Gently push the cards into the corresponding slot along the guide rail;
 3. When it approaches the backplane connector, press the latching devices on the handles of the panel with both hands and open them outward; then hold the chassis inward with force and push the panel inward;
 4. After confirming the card is properly seated, fasten the handle with the chassis.

5.2.2 Removing the Front/Rear Add-in Card

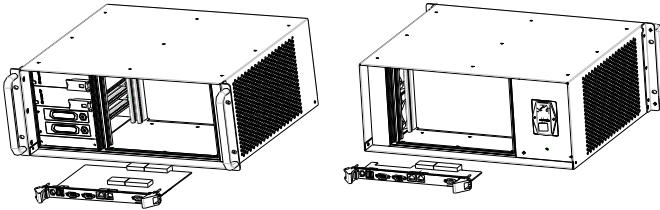

- 1) When removing the front/rear add-in card, please do as follows:
 1. Press the latching device on the handles of the panel with both hands and open outward; hold the chassis and pull outward with force until it breaks away from the backplane connector;
 2. Take out the add-in card along the guide rail and lay the card at a safe place.

5.3 Removal and Installation of Driver

- 1) Please turn off the system power, when replacing the system hard disk; while the hard disk other than the system hard disk is required to be replaced, there is no need to turn off the system power. Open the lock with key; press the left side of the embedded handle in the middle of the drawer door to make it pop up; hold the handle to pull out the hard disk together with the hard disk drawer; (refer to the figure below)

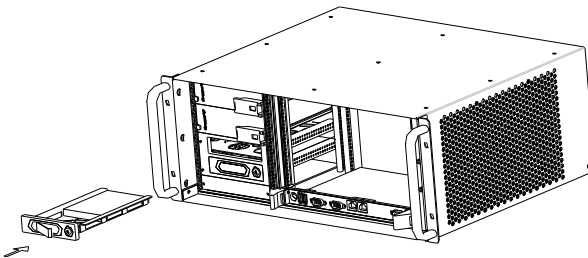

- 2) When replacing the hard disk, please remove the four screws fixing the hard disk, take out the hard disk, locate it at a safety position and replace it with a new one. When installing a new hard disk, please fix the four screws. (Note: the fixing screws are M3 countersunk head screws; please make sure the screw heads are in the same level with the bottom of the hard disk guide rail bracket after fastened.)

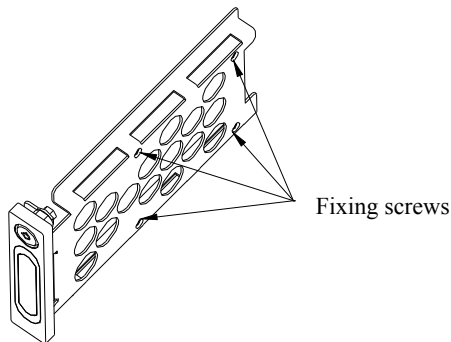

- 3) Install the well-assembled hard disk and hard disk drawer back into the chassis; make sure the hard disk has been connected with the connector on the backplane; lock with key and make sure the lock bolt has entered the fixing hole.
- 4) The hard disk can be used normally once it has been identified by system.

5.4 Removal and Installation of Power Supply

Danger

Before removing the power module, please turn off the power and remove the power cord if any power has been connected.

Exclusive power module has been installed within the CPC-8408B chassis before delivery. Please do as follows when replacing a new power module:

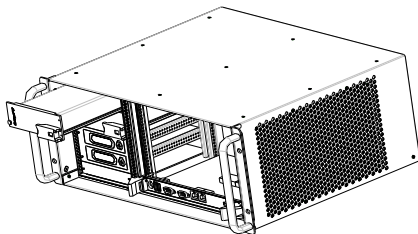

- 1, Loosen the fixing screws on the panel of the power module until it breaks away from the chassis;
- 2, Pull the handle of the power module outward until it breaks away from the backplane connector; draw out the power module along the guide rail and wrap the module with exclusive packing material
- 3, Make sure the input mode of the power module meets the system requirement;
- 4, Make sure the panel handle is open; insert the power module into the chassis along guide rail gently until the hooks on the panel handles enter the fixing holes of the chassis; then hold the panel stably and press the power inward with force until the handles are tightened;
- 5, After tightly inserting the power module into the chassis, fasten the panel with the chassis by screws;
- 6, Observe the indicator on the panel of the power module, if it displays normally after powering on, then it can be used.

5.5 Assembly and Maintenance of Fan and Dust-proof Net

Note:

Because the fan speed is relatively fast, please do not touch the fan before it stops.
--

During using, the fan or the dust-proof net might be damaged; please power off the device before replacing. Please follow the steps below:

- 1) Loosen the screws on the front panel of the fan, hold the handle of the front panel of the fan with fingers and then pull the fan module out of the chassis (refer to the figure below);

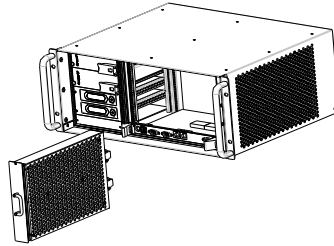

- 2) When replacing the dust-proof net, please remove the fixing screws marked as 7 in the figure below and then take out the fan bracket together with the fan; When replacing the fan, please remove the fan fixing screws marked as 4 in the figure below, replace with a new one and assemble the screws back;

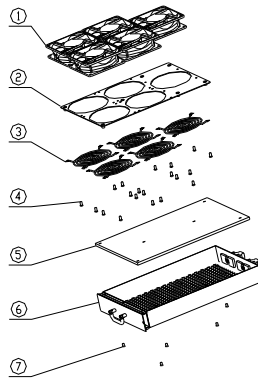

Item	Description	Item	Description
1	Fan	2	Fan bracket
3	Fan net	4	Fan fixing screw
5	Dust-proof net	6	Fan module
7	Fixing screw for fan bracket		

6. Installing the Drivers

Regarding the installation of the driver program and the detailed information of the motherboard, please refer to the enclosed CD of the PC.

7. Appendix

7.1 Troubleshooting and Solutions

Common Malfunctions	Reasons	Troubleshooting and Solution
The device is not operating	No power supply	Please check the power supply and the power cable/connector.
	Improper device operating environment	1. Check with the environment conditions; 2. Please wait for twelve hours before powering on the device shipped in cold weather.
The external display is black	The display has not been turned on	Turn on the display
	The display is under “power saving” mode	Press any key on the keyboard.
	The luminance control is set to “Black”.	Increase the screen luminance by luminance control. Please refer to the instructions of the display for detailed information.
	Power cable or display cable is not connected	1. Please check whether the power cable is correctly connected with the display, the system unit or the ground port. 2. Please check whether the display cable is correctly connected with the display and the system unit. 3. Contact Technique Support if the screen remains black after implementing the above measures.
Incorrect time or date on PC	Incorrect BIOS setting	Follow the power-on prompt and press the key to enter the BIOS Setup; adjust the time and date in BIOS Setup.

BIOS setting is correct while the time and date are incorrect.	Insufficient backup battery capacity	Replace the battery
USB device has no response	USB port is disabled in BIOS	Use other USB ports or enable that port.
	USB 2.0 device is connected; however, USB 2.0 is disabled.	Enable USB 2.0.
	USB port is not supported by the operating system.	1. Enable USB Legacy Support for the mouse and keyboard (Legacy USB is supported); 2. For other devices, appropriate USB drivers are required.
The computer is not booted or displays “Boot device not found”	In booting priority of the BIOS setting, the device is not the first priority or the device is not include in the booting device.	Modify the booting priority of the device in the Boot menu of BIOS setting or include that device into the boot priority.
No system disk can be found when powering on	The HDD power cable or data cable is not connected well	Check whether the power cable and the data cable of the hard disk (the hard disk shall be installed with operating system and is bootable) are well connected.
	System files on the hard disk are damaged	Enter the system (usually winPE system) with a bootable disk; check whether the system in the hard disk is damaged. Reinstall the system if necessary.
Plug and play I/O card, no IO card is detected or no IO card can be used when used again	Poor contact of the slot	Poor contact is usually caused by frequent installation/uninstallation of the PCI or ISA card, unstable fixing or improper dust-proof measures; please remove and install the card for a few times or use another slot.